



The lack of information on the scope of LGU responsibilities can be seen as one stumbling block to proper and timely management. This section identifies major CRM issues and determines the jurisdictional authority of LGUs or NGAs in addressing these issues. Five major CRM issues are analyzed here: open access, habitat destruction, resource enhancement, law enforcement, and development activities. Each of these issues then becomes a nucleus branching out into various spokes which are minor clusters of issues or expansions of the mother issue, thus the term *Problem Network*. For example, there are several facets of the coastal law enforcement issue (the nucleus): apprehension, prosecution, and imposition of penalty (the spokes). Meanwhile, the spokes corresponding to the open access nucleus, such as licensing, lease agreements, and property rights, are actual resolution mechanisms. For the rest, the resolution is implicit as the network eventually branches out to specific elements. Conflict resolution is realized when the appropriate agency, whether the LGU or the NGA, acts upon it. Nevertheless, the first step is to ascertain responsibility — this is what this section strives to achieve.

The problem networks respond to three critical questions:

- 1) What is the major CRM issue to be addressed?
- 2) Who may address such issue?
- 3) What is the legal basis for this?

**What is open access?** An open access situation exists when the resource, usually state-owned or public property, is available for all to utilize. Any individual, or any number of individuals, have the right to use such resource without fear of present or future exclusion. Unless property regimes exist, a marine resource is often an open access resource. In the past, forests (including mangroves) were also open access resources; today, enough policies have been instituted to regulate their use.

**What happens to the resource when open access exists?** Resource degradation and dissipation of economic rent<sup>1</sup> are very often the end results of an open access situation. In a fishery, open access leads to a sub-optimal number of fishers chasing fewer and fewer fish. The increasing pressure to catch more fish is aggravated by the use of deleterious fishing gears, cyanide, and dynamite fishing, causing damage not just to the fish but also to the habitats that support them. The open access condition is worsened by the absence of alternative employment conditions in the other economic sectors. Meanwhile, economic rent dissipation occurs when there is overcapitalization and oversupply

## 4.1 OPEN ACCESS

<sup>1</sup> Net benefits accruing to society from resource use over and above opportunity costs.





of labor in the fishery resource.

*How is an open access situation managed?* The need to regulate becomes essential not just in determining the numbers of participants but also in the intensity of resource use. Several mechanisms are analyzed to respond to one or both of these problems. These include 1) issuance of license and permits; 2) taxation; 3) lease or rental fees; 4) restrictions; and 5) the assignment of property rights (Figures 4-1 to 4-6). Auxiliary invoices are issued for monitoring the flow and transport of fishery products; they do not have an exclusionary effect, except for those who are unwilling to pay the fee (based on volume of shipment). Nevertheless, invoices are lumped together with licenses and permits because of similarity in their design.

Access may also be limited to restricting resource use. Restrictions may be spatial, temporal, or technological in nature. Area restrictions prohibit certain types of activities within an area. For fishing, the area restriction is essentially the boundaries of municipal waters (as defined by law) and, within this zone, a demarcated fishing area. Temporal restrictions, such as closed seasons, have been used mainly to rejuvenate the resource. In most cases, a combination of restrictions (e.g., area and gear) is used. Gear and mesh size restrictions are analyzed within the framework of enforcement because the jurisdictional question is more acute.

The assignment of property rights confers on a particular aggrupation (which may theoretically include a private individual) the management and sometimes exclusive use of certain or entire fishing zones. FARMCs, as an institutionalization of fisherfolks' involvement in resource management, may be viewed as an "indirect" assignment of rights to manage municipal waters. A derivative of property rights is preferential treatment, which limits, to a certain extent, the participation of outsiders in a process. In both cases, the exclusion of individuals becomes possible and regulation can be developed by the resource stewards.

The problem network indicates that limitations on resource use, like the granting of licenses and permits for fisheries, are within the jurisdiction of the LGU. The LGC stresses the preferential treatment for cooperatives of marginal fishers (Sec. 149). The conferment of property rights to selected segments of communities was also realized by DENR when it developed its Mangrove Stewardship Agreement (DAO 3, s 1991). In the same manner, small-scale mining cooperatives covered by RA 7076 are given preferential right to apply for a small-scale mining agreement for a maximum aggregate area of 25% within declared mineral reservations (Section 22, DAO 23, s1991).

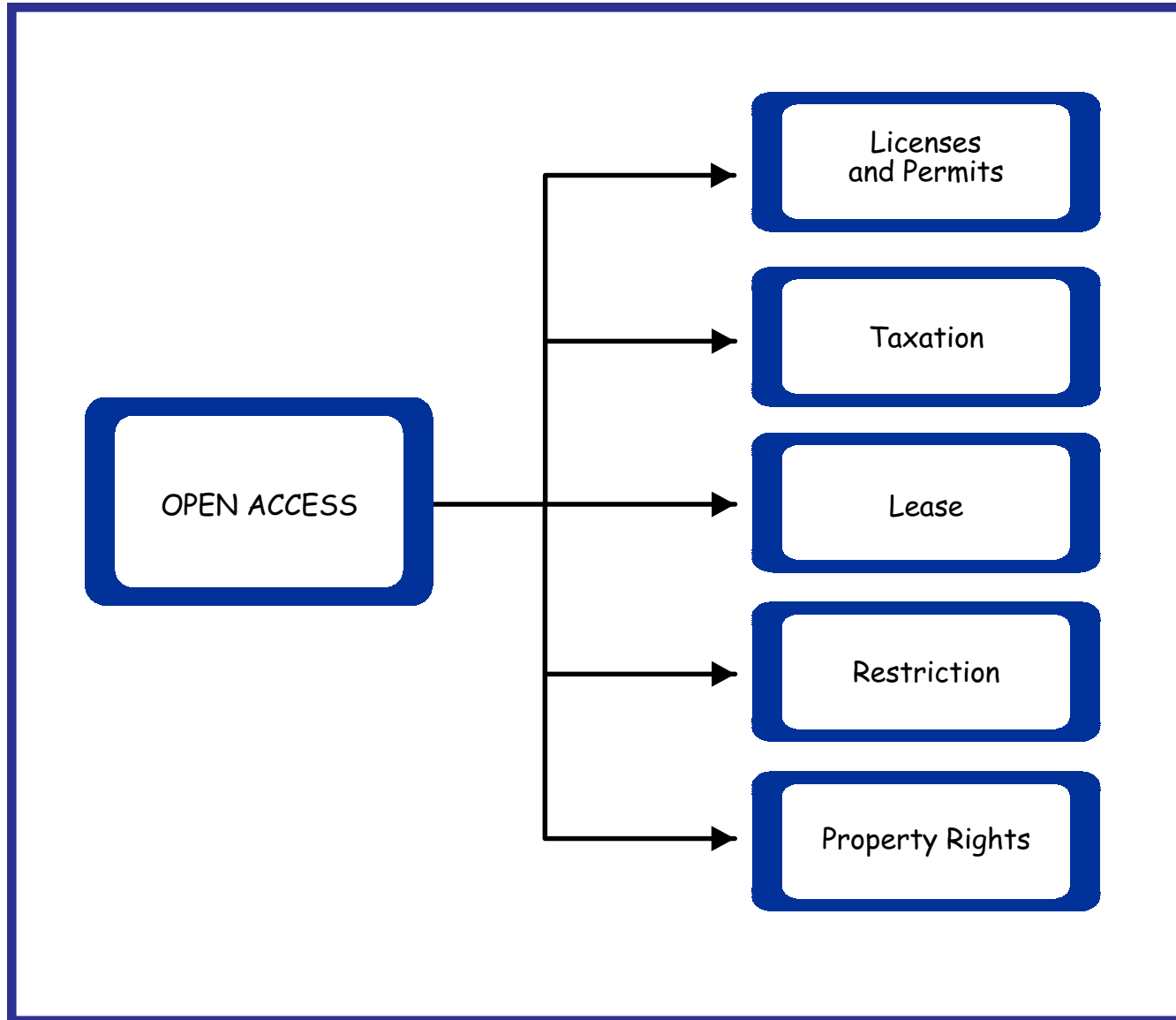

FIGURE 4-1.  
CRM PROBLEM NETWORK  
No. 1: OPEN ACCESS



# 4

## CRM Problem Networks and Jurisdictional Authority



**FIGURE 4-2.**  
**CRM PROBLEM NETWORK**  
**No. 1: OPEN ACCESS - LICENSES**  
**AND PERMITS**

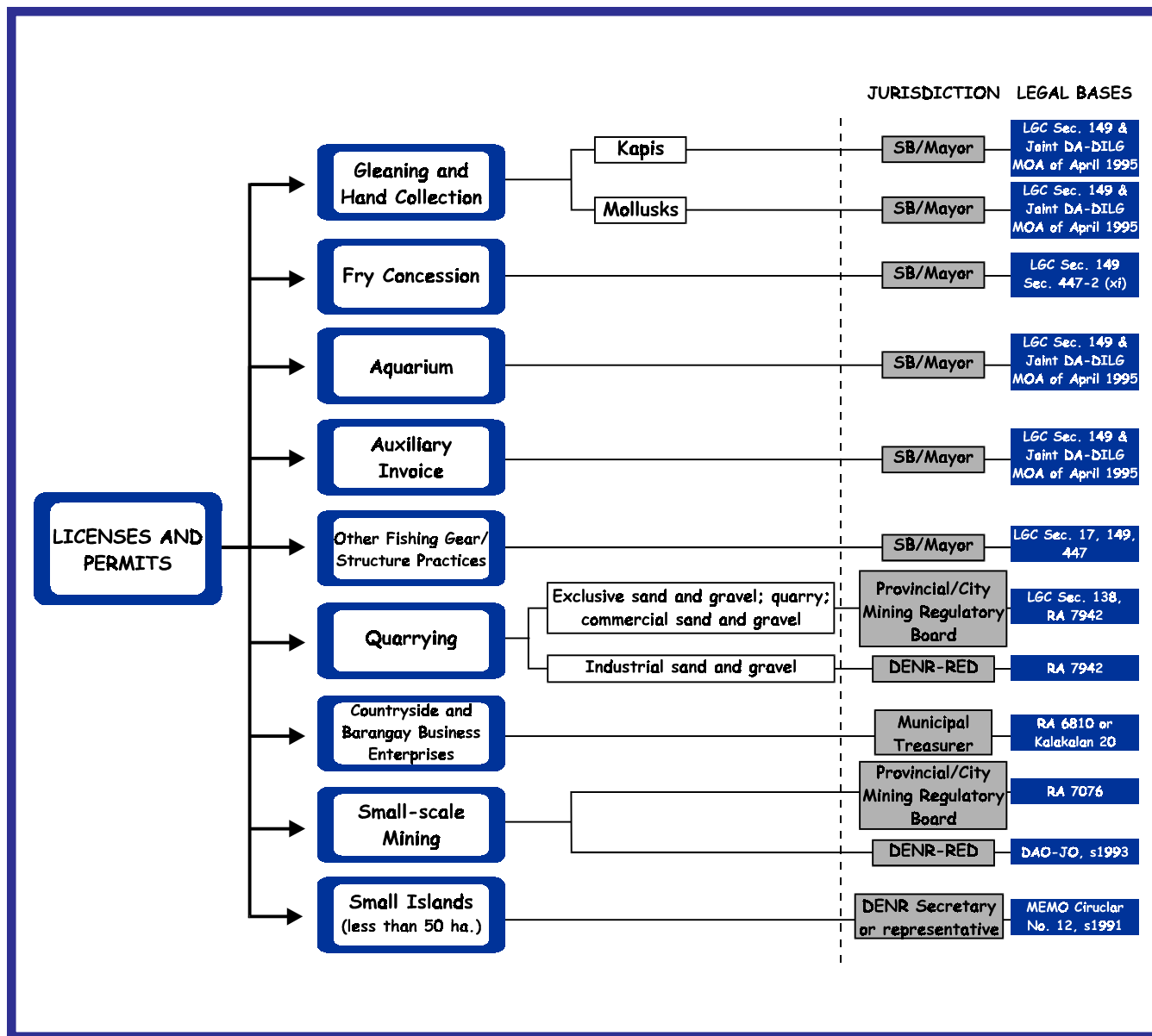

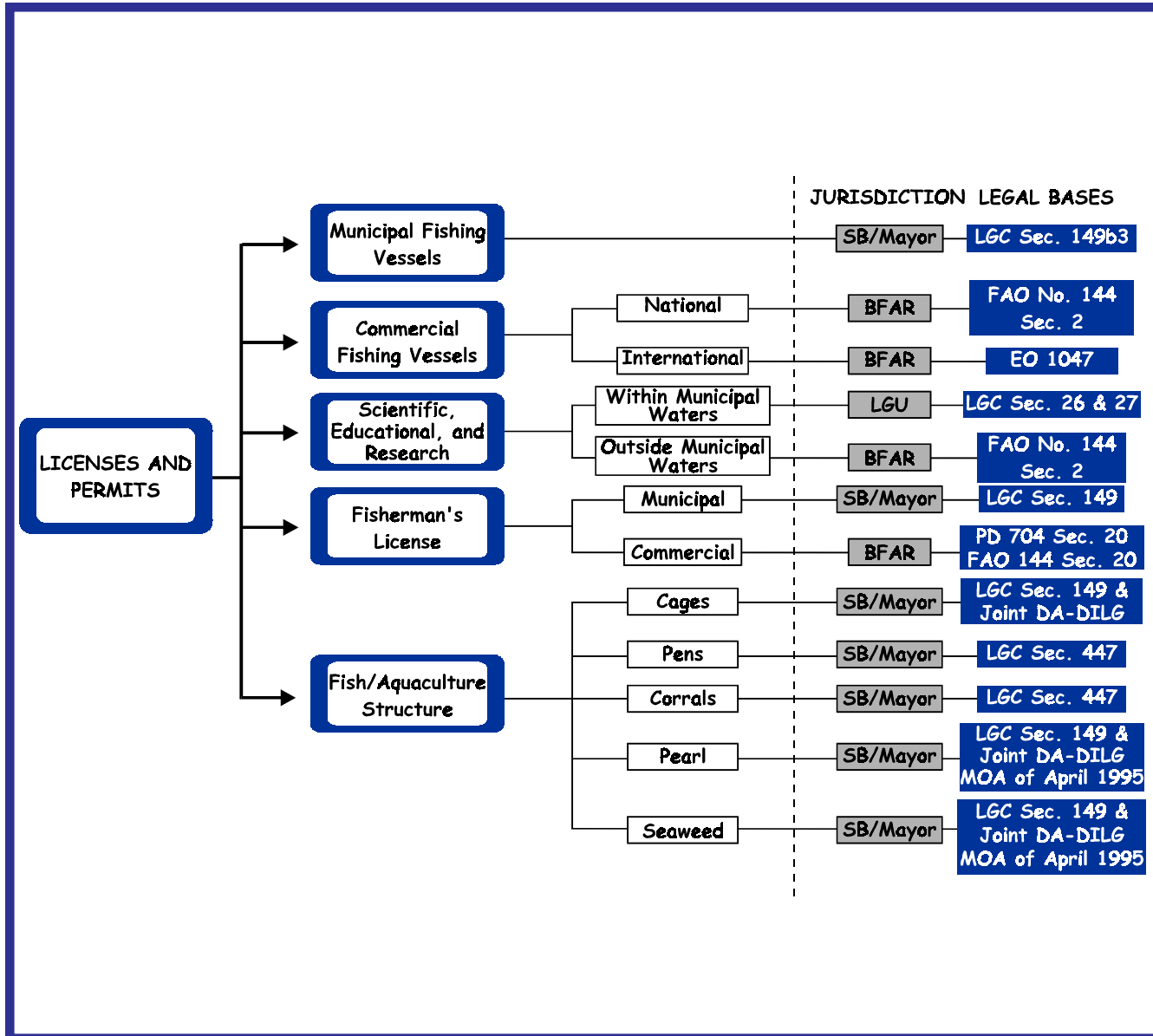

FIGURE 4-2. (CONTINUED)  
CRM PROBLEM NETWORK  
No. 1: OPEN ACCESS - LICENSES  
AND PERMITS



# 4

## CRM Problem Networks and Jurisdictional Authority



**FIGURE 4-3.**  
**CRM PROBLEM NETWORK**  
**No. 1: OPEN ACCESS - TAXATION**

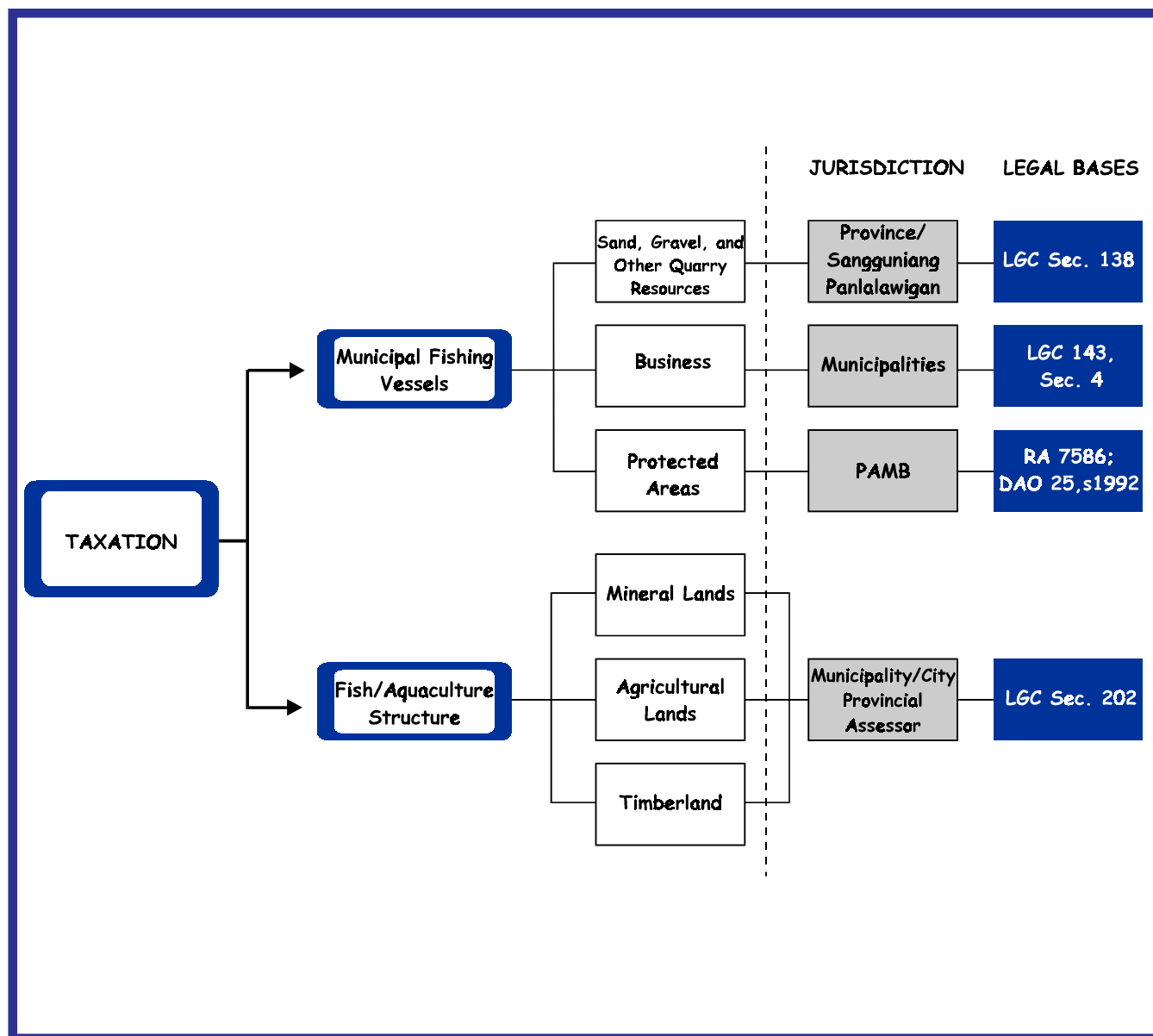

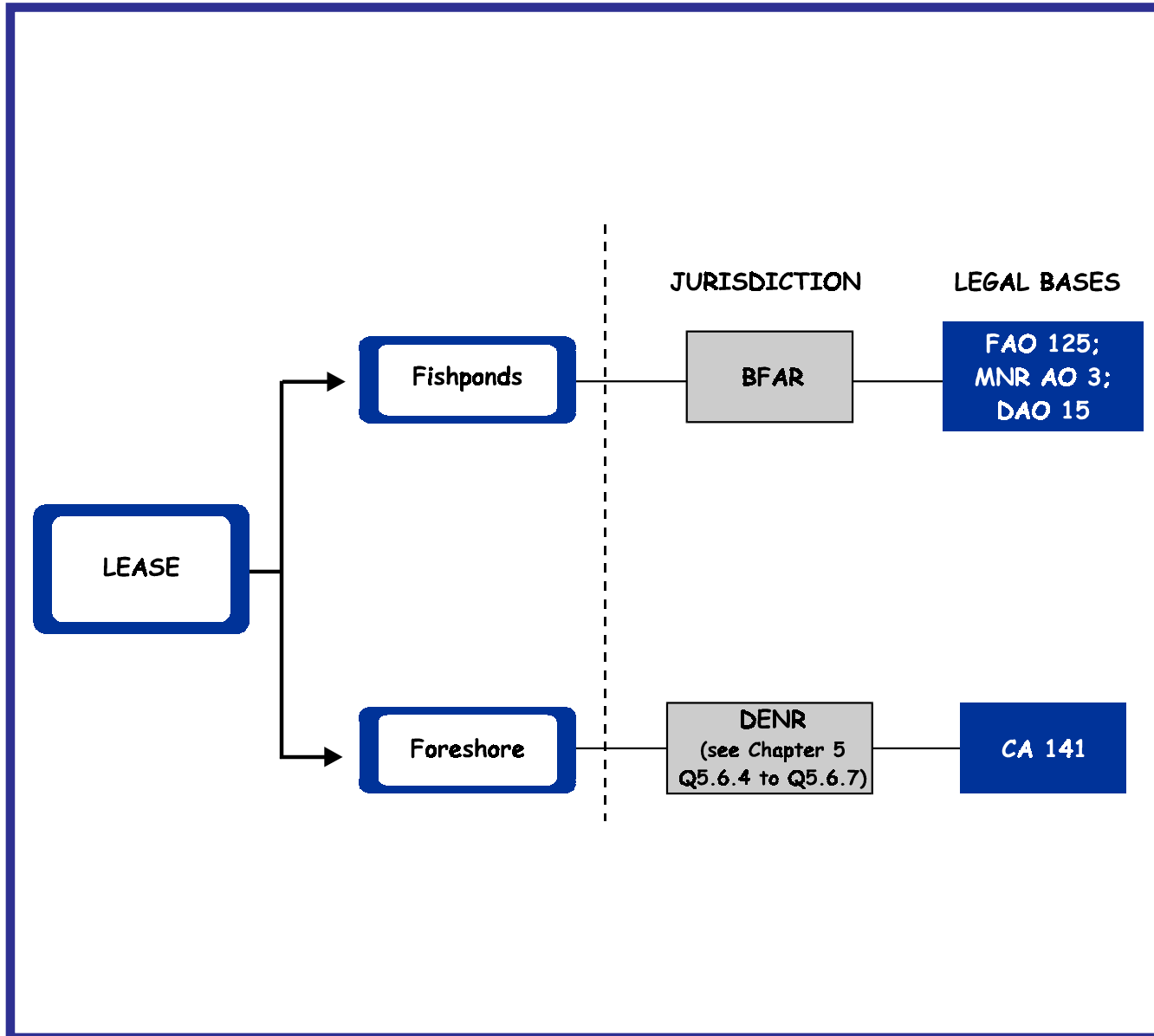

FIGURE 4-4.  
CRM PROBLEM NETWORK  
No. 1: OPEN ACCESS - LEASE



# 4

## CRM Problem Networks and Jurisdictional Authority



**FIGURE 4-5.**  
**CRM PROBLEM NETWORK**  
**No. 1: OPEN ACCESS -**  
**RESTRICTIONS**

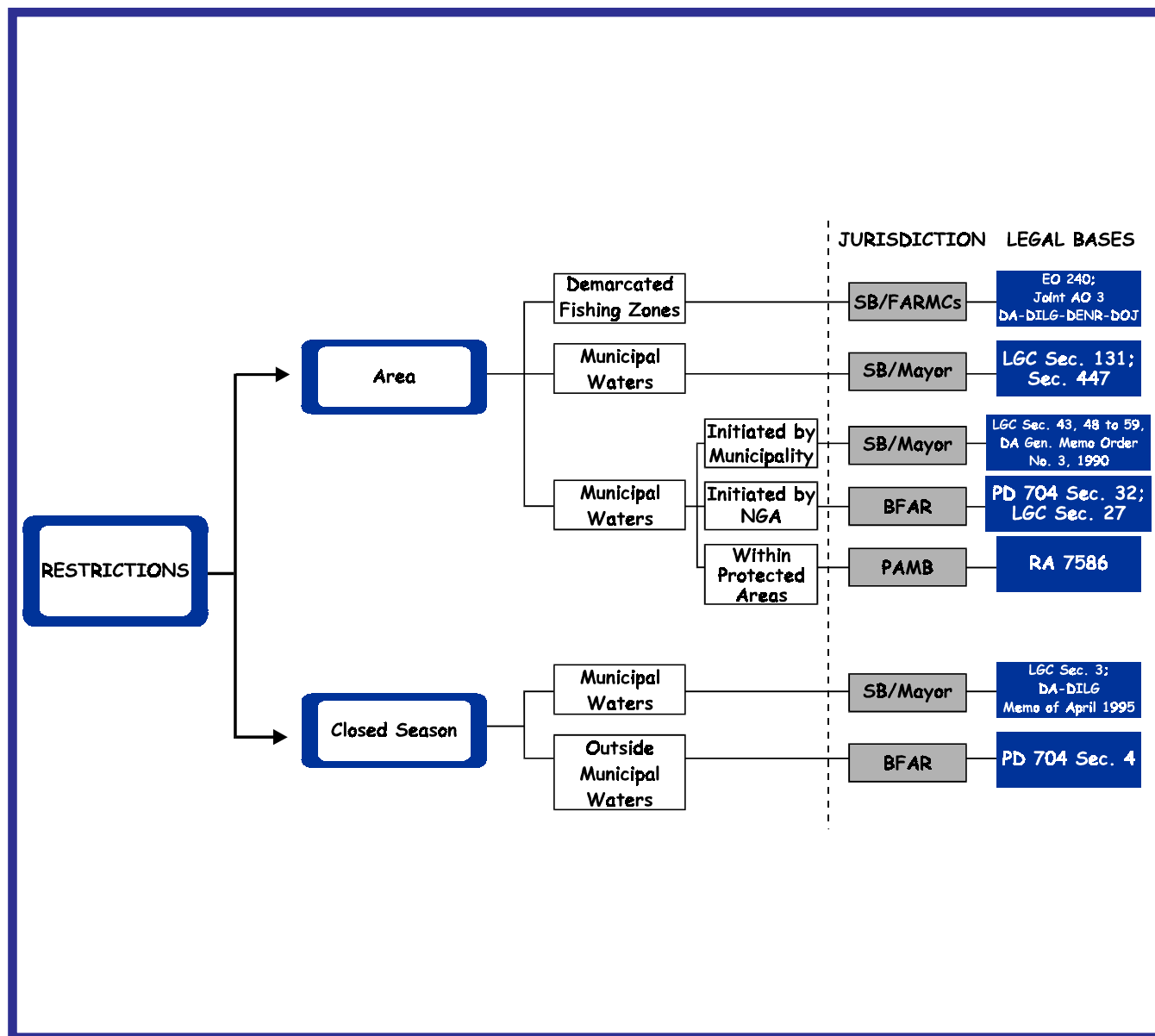

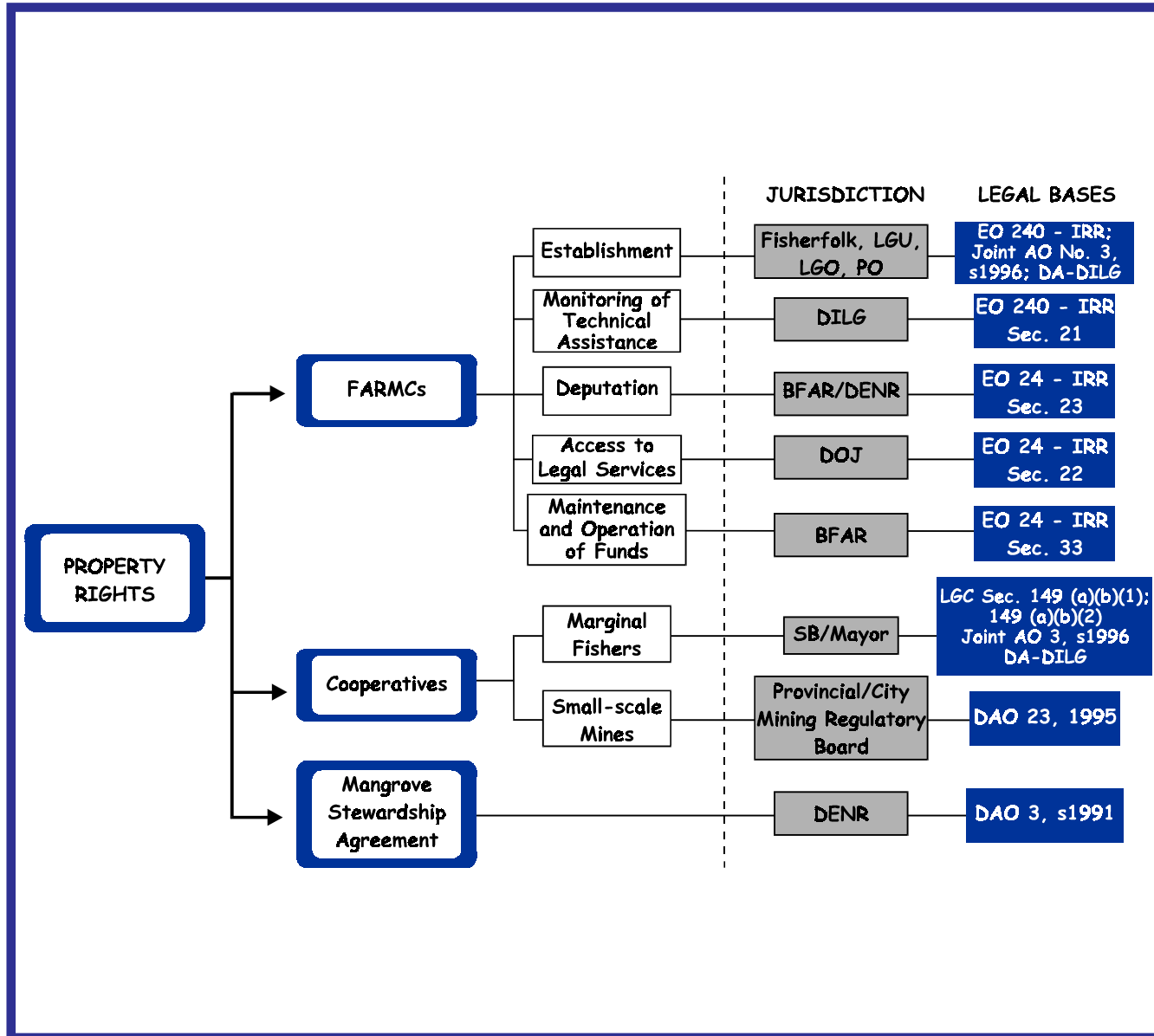

FIGURE 4-6.  
CRM PROBLEM NETWORK  
No. 1: OPEN ACCESS - PROPERTY RIGHTS



# 4

## CRM Problem Networks and Jurisdictional Authority



### 4.2 HABITAT DESTRUCTION

Habitat destruction is an important CRM issue not only because of the loss of goods and services derived from coastal ecosystems but also because of the partial or total impairment of important ecological functions (Figures 4-7 to 4-9). Mangrove and coral reef systems are considered here because of their vulnerability to man-made threats and the numerous economic and ecological benefits attributed to them. Mangroves are sources of fishery and forestry products; they are also an important nursery ground for juveniles of fish. Coral reefs provide habitats to fishery resources and protection against tidal surges and storms as well as enhance the aquatic environment.

Two classes of factors causing destruction are evaluated here: (1) direct factors, i.e., activities which directly and/or immediately cause partial or total damage and (2) indirect factors or externalities which are effected by activities external to the coastal system but which nevertheless have a long-term, and at times irreversible, impact on these systems. The direct factors considered here include coral mining which is an extractive activity causing the actual removal of corals from their habitat; blast fishing which results in immediate reef destruction; and cyanide fishing, which while targeting reef fish, eventually causes the destruction of coral polyps. Deleterious methods of fishing, such as *muro-ami* and *pa-aling*, utilize similar procedures, like driving and scaring fish into nets by using lines or pounding on corals. Problems pertaining to coral reef destruction can be addressed by the LGUs through the enforcement of existing national laws or through legislation as provided for by the LGC.

Conversion completely obliterates the ecological and economic attributes of mangroves. The jurisdiction for mangrove use and management is lodged with DA-BFAR and DENR. DA-BFAR retains its role in the issuance of lease agreements and monitoring of fishpond productivity in areas released for fishpond purposes while DENR is involved in the general area of mangrove management including reforestation. DENR also requires fishponds to submit ECCs. The scope of LGU jurisdiction for mangroves is limited to that provided for in DAO 30, s1992 and the enforcement of national laws.

Pollution and siltation are problems caused by terrestrial and upland activities such as mining, forestry, and agriculture. Two types of establishments are considered here to highlight the jurisdictional issue: Community and Barangay Business Enterprises (CBBEs) and non-CBBEs. CBBEs are within the jurisdiction of the municipalities or cities with devolved environmental management functions, such as the issuance of ECCs and the adjudication of pollution cases involving complaints against CBBEs (DAO 30, s1992). CBBEs registered with the Department of Trade and Industry between 1991 to 1994 are not covered by the EIS system. For CBBEs which have been registered after 1994, exemption from the EIS system is valid for a period of 5 years beginning from their date of registration; thereafter, they shall be subject to DENR's EIS system (DAO 96-37, s1996).

Pollutants from non-CBBEs such as oil spills, mine tailings and hazardous wastes are not within the jurisdiction of the LGU (Figure 4-7). Siltation problems are within the jurisdiction of the LGU, specifically the province (LGC, Section 17), and the barangay (LGC Sec. 389(a)(9)), PD 1160); where the cause has been ascertained to come from



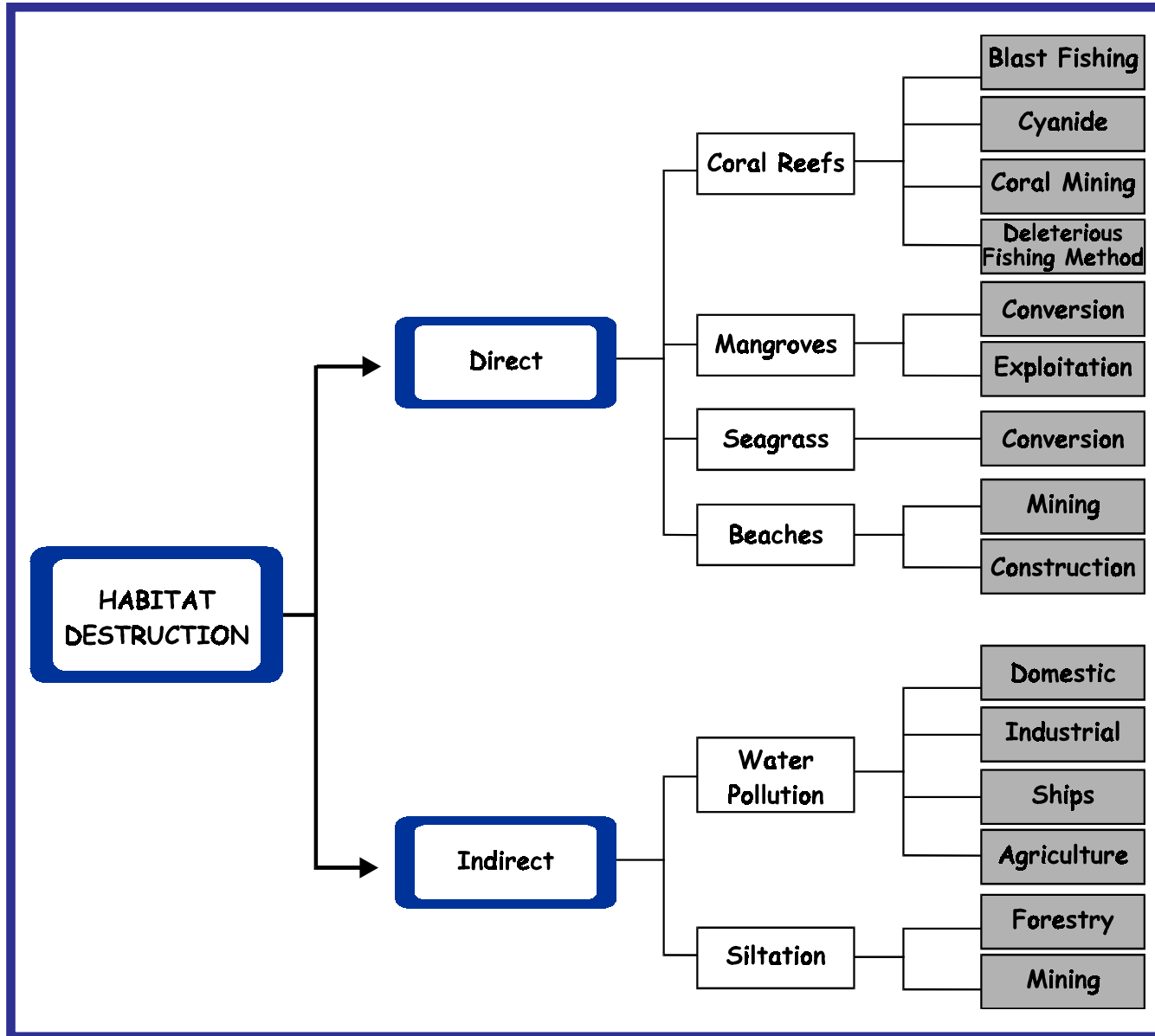

FIGURE 4-7.  
CRM PROBLEM NETWORK  
No. 2: HABITAT DESTRUCTION



# 4

## CRM Problem Networks and Jurisdictional Authority



**FIGURE 4-8.**  
**CRM PROBLEM NETWORK**  
**No. 2: HABITAT DESTRUCTION -**  
**DIRECT**

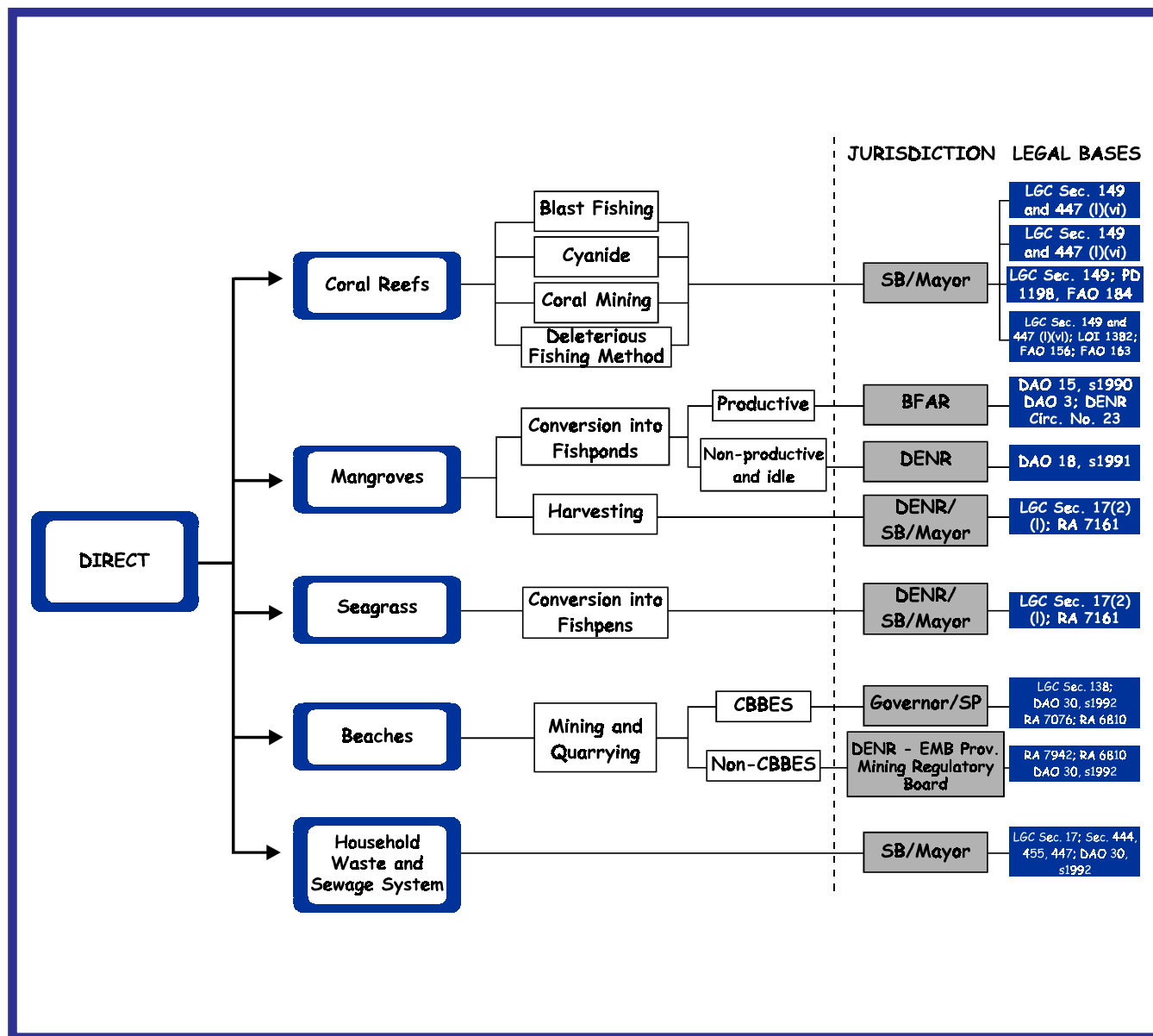

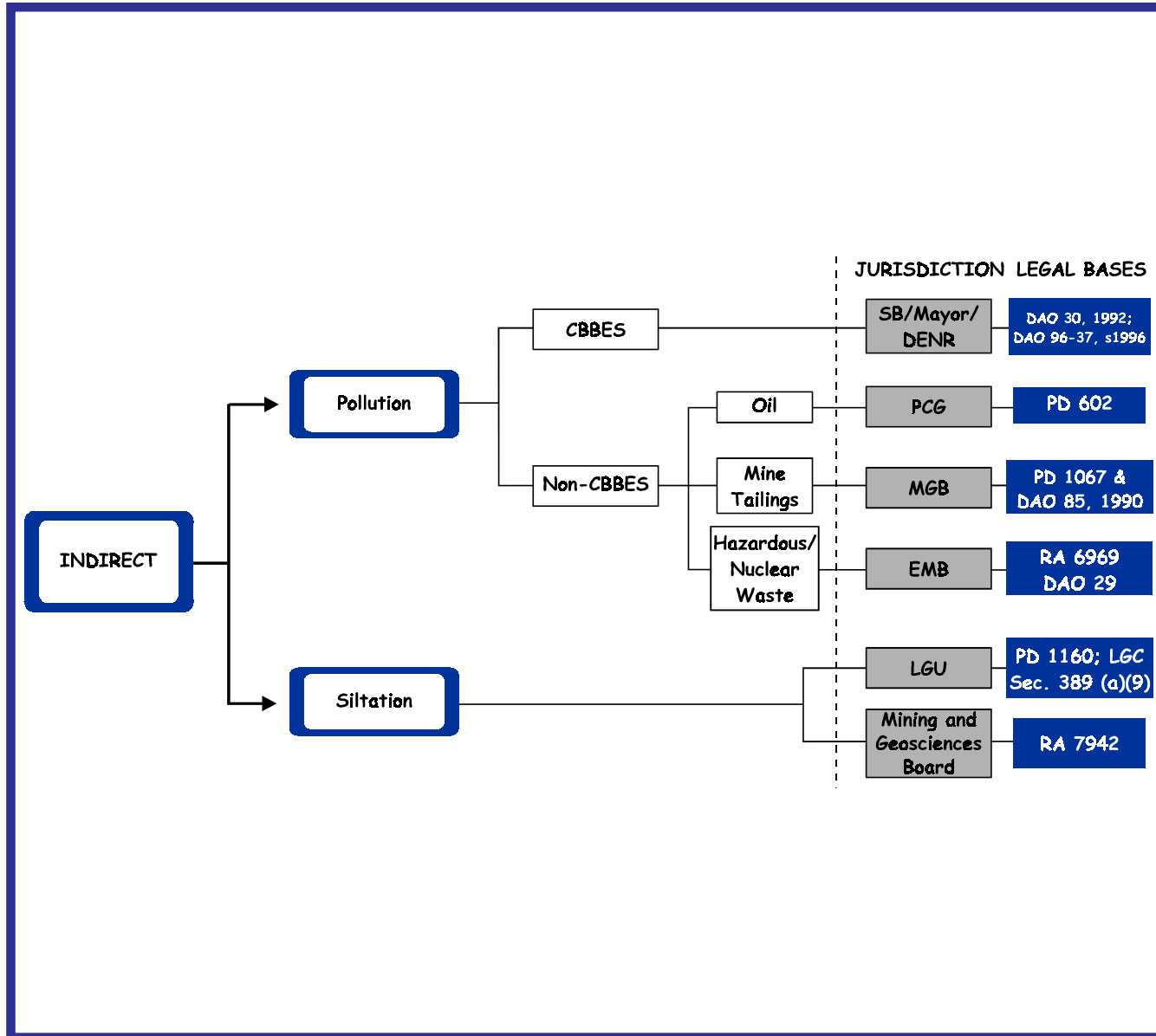

FIGURE 4-9.  
CRM PROBLEM NETWORK  
No. 2: HABITAT DESTRUCTION -  
INDIRECT



# 4

## CRM Problem Networks and Jurisdictional Authority



mining operations, the DENR-MGB may issue cease-and-desist orders while the DENR-EMB may require the permit-holder to remedy the practice that violates anti-pollution laws and regulations.

### 4.3 ENFORCEMENT

Enough laws have been written to manage our resources but enforcement is extremely weak. There are two reasons for this: the slow process of justice and the system of “incentives” that encourage people to break the law. Enforcement, as analyzed here, involves all processes from apprehension to prosecution (Figures 4-10 to 4-12). The first level of enforcement, apprehension, already faces logistical bottlenecks, such as the lack of patrol vehicles and trained personnel, especially for fisheries. When apprehension is successful, there is no guarantee that the case will sufficiently progress and reach prosecution level. For one, there is a dearth of legal practitioners familiar with CRM. (Data generated by the FSP show that most apprehensions have not progressed sufficiently to reach the prosecution stage.) The “incentive” system for thwarting the law is borne by a token system of penalties, the *padrino* system, the tolerance and espousal of short-term solutions such as dynamite fishing (which usually translates to destructive resource use) and the lack of political will among the leaders.

Enforcement approaches can either be positive (encourage compliance with the requirements of the law without going to the courts) or negative, for which legal sanctions are imposed. The latter is exercised by a competent authority like an administrative regulatory body or any court having appropriate jurisdiction when criminal and civil aspects are involved (Castillan 1977).

Enforcement can be carried out either by administrative sanctions or by the Court (Tolentino 1992). “Administrative sanctions are frequently used in environmental law enforcement as defined in the implementing rules and regulations.” In such cases, penalties can be meted out by the regulatory agency without court proceedings. This system normally provides for an administrative appellate procedure with final appeal to a competent court. Meanwhile, the courts provide the venue for administrative agencies “to seek enforcement of their needs and review of actions of administrative agencies to see to it that functions are performed in a proper manner.”

The importance of the judicial institution in the implementation and enforcement of environmental laws cannot be overemphasized due to the following:

- ◆ The novelty of environmental law and the consequent necessity of defining new terms and concepts and redefining old ones



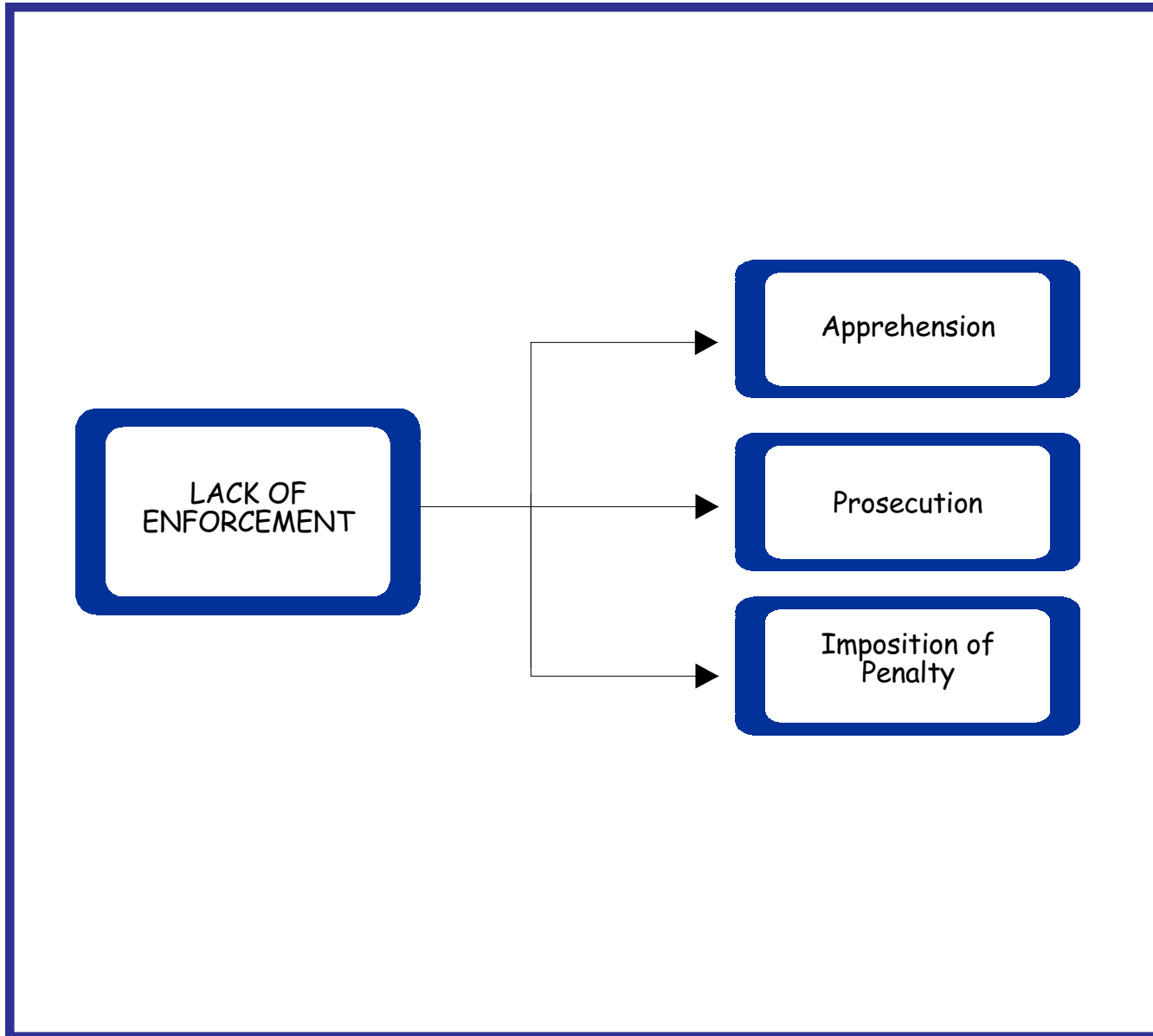

FIGURE 4-10.  
CRM PROBLEM NETWORK  
No. 3: LACK OF ENFORCEMENT



# 4

## CRM Problem Networks and Jurisdictional Authority



**FIGURE 4-11.**  
**CRM PROBLEM NETWORK**  
**No. 3: LACK OF ENFORCEMENT -**  
**APPREHENSION**

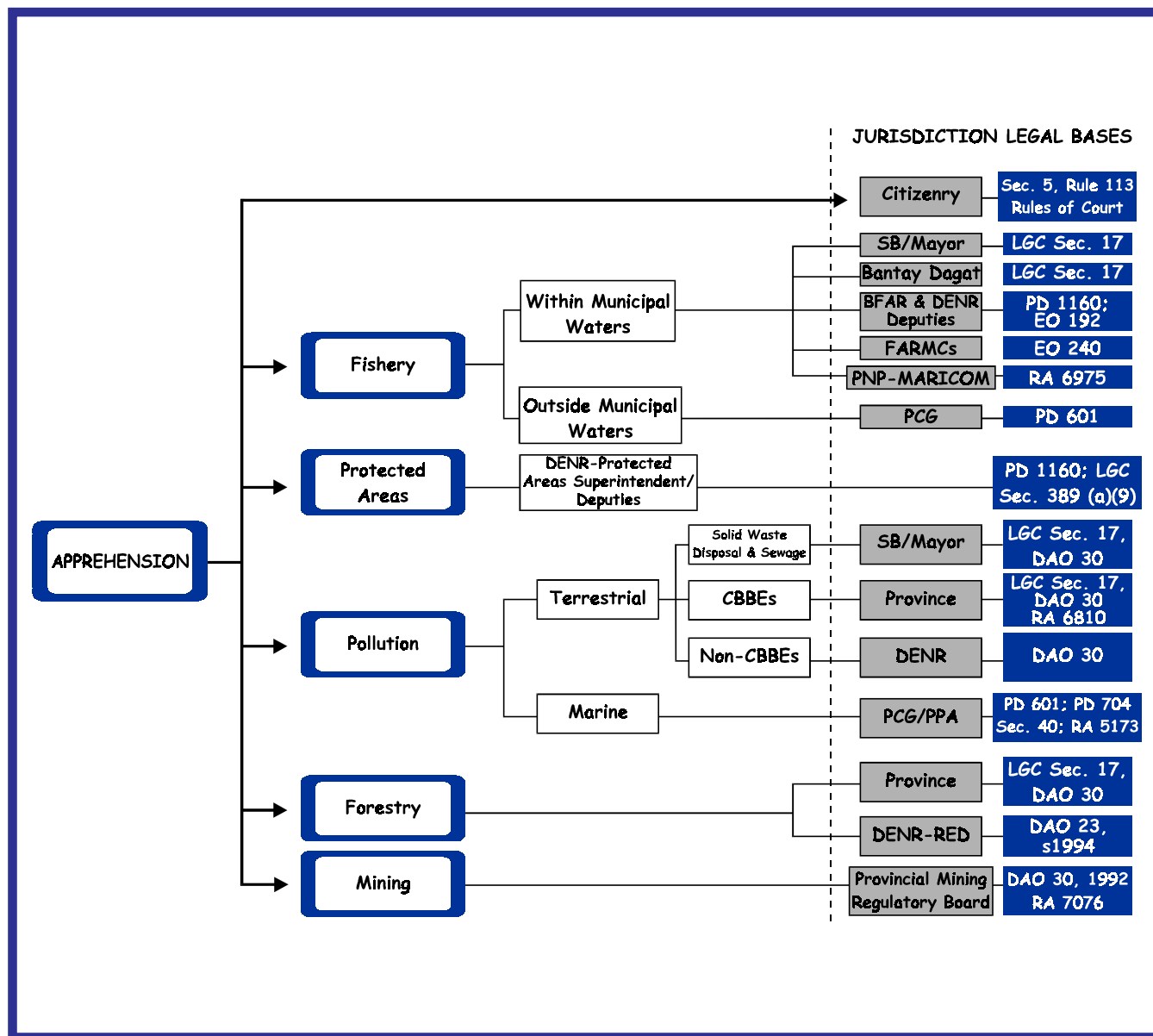

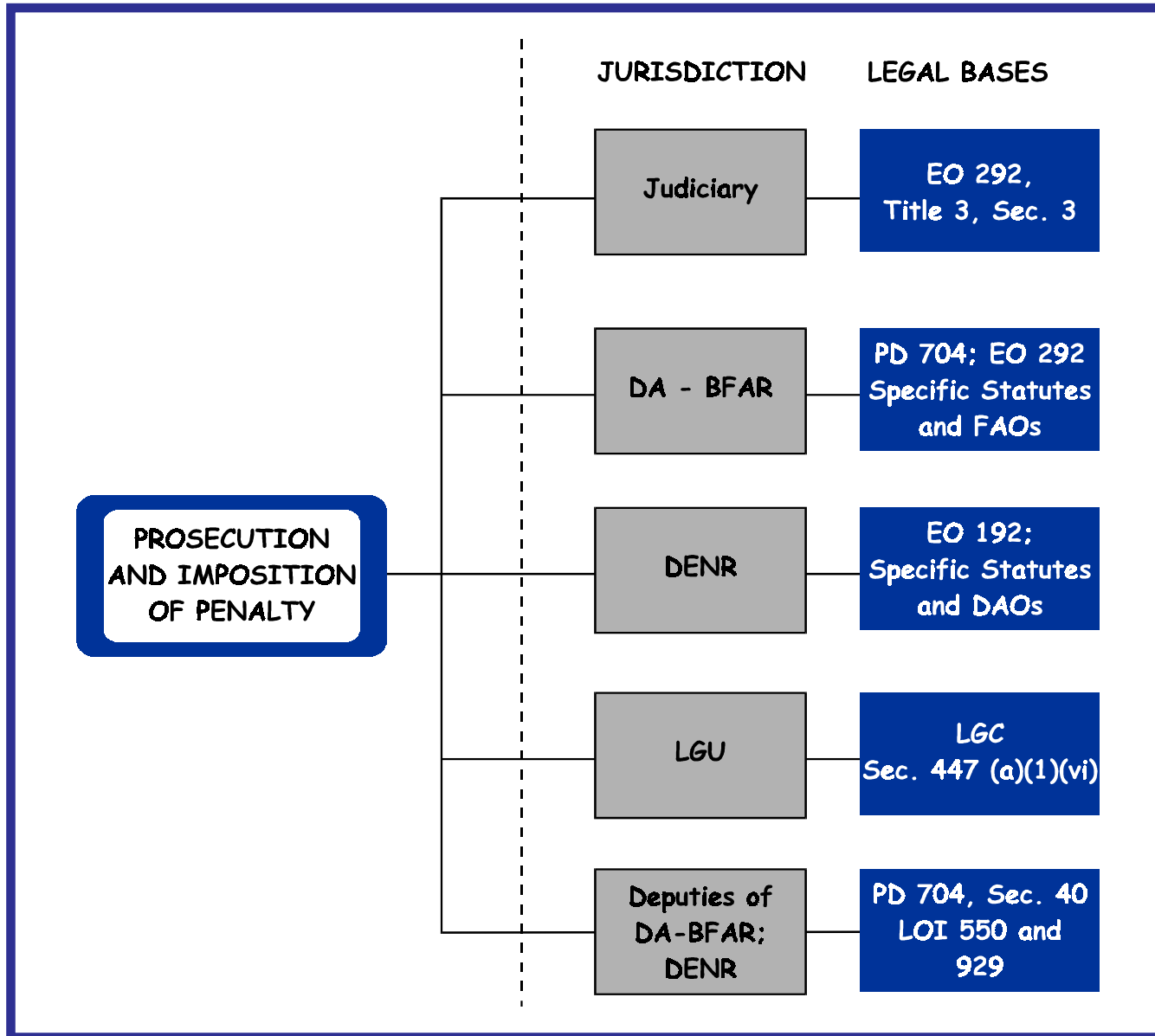

FIGURE 4-12. CRM PROBLEM NETWORK No. 3: LACK OF ENFORCEMENT - PROSECUTION AND IMPOSITION OF PENALTY



# 4

## CRM Problem Networks and Jurisdictional Authority



- ◆ The importance of the right asserted in environmental cases arising out of the irrevocable impact of environmental decisions justifies more thorough-going judicial review
- ◆ The value judgments present in environmental cases call for the talents and training of the courts and judges rather than those of administrators (ESCAP 1977)

Administrative sanctions pertaining to the enforcement of environmental laws are lodged in the DA-BFAR for fishery laws and DENR for environmental laws. These are found in various national laws as well as DAOs. However, it is difficult to impose administrative fines because national agencies do not have sufficient field staff to monitor compliance. The LGU can fill this void by enacting ordinances which impose fines as provided for by the LGC. While national laws already exist, and there is a case against double jeopardy, local level ordinance can deal with specific offenses not covered by national laws. Such enforcement is akin to an administrative sanction. It must be stated, however, that this LGU function does not dilute nor diminish the powers of the Department Secretaries (and their representatives) to impose fines as they are enabled by different laws.

The enforcement network developed to identify jurisdictional responsibilities shows the extent of authority of LGUs, particularly with respect to fishery laws (both ordinances and national laws). This authority, however, is shared with NGAs, which is why shirking of responsibilities is common.

### 4.4 RESOURCE ENHANCEMENT AND CONSERVATION

Resource enhancement and conservation are viewed as positive strategies for management rather than mere defensive techniques (Figures 4-13). The LGU can be at the forefront of resource enhancement and conservation initiatives by enforcing subsisting laws or by enacting ordinances specific to their localities. Several national laws and AOs that deal with conservation and resource enhancement exist including, for fisheries, specific FAOs for the conservation of 1) milkfish (FAO 129 and 173); 2) marine tropical aquarium fish (FAO 148); 3) *kapis* and other mollusk species (FAO 157 and 158); 4) coral resources (PD 1219 and 1198); and 5) marine turtles, eggs, and shells (FAO 29, 76 and 88). In addition, the declaration of closed seasons has been devolved to LGUs and the establishment of fish sanctuaries is entirely within the jurisdiction of the LGU. There is no single entity with monopoly over the guidelines and policies for artificial reef (AR) deployment, an enhancement technique that has gained wide popularity in local communities. Nevertheless, this document mentions the current move of DENR, DA-BFAR, DILG, and DND to declare a temporary moratorium on AR deployment pending further scientific inquiry.

The NIPAS Law (RA 7586) is the country's centerpiece for protected area management. Various Presidential Proclamations have also established protected seascapes. On the subject of potential conflicts between the PAMB and



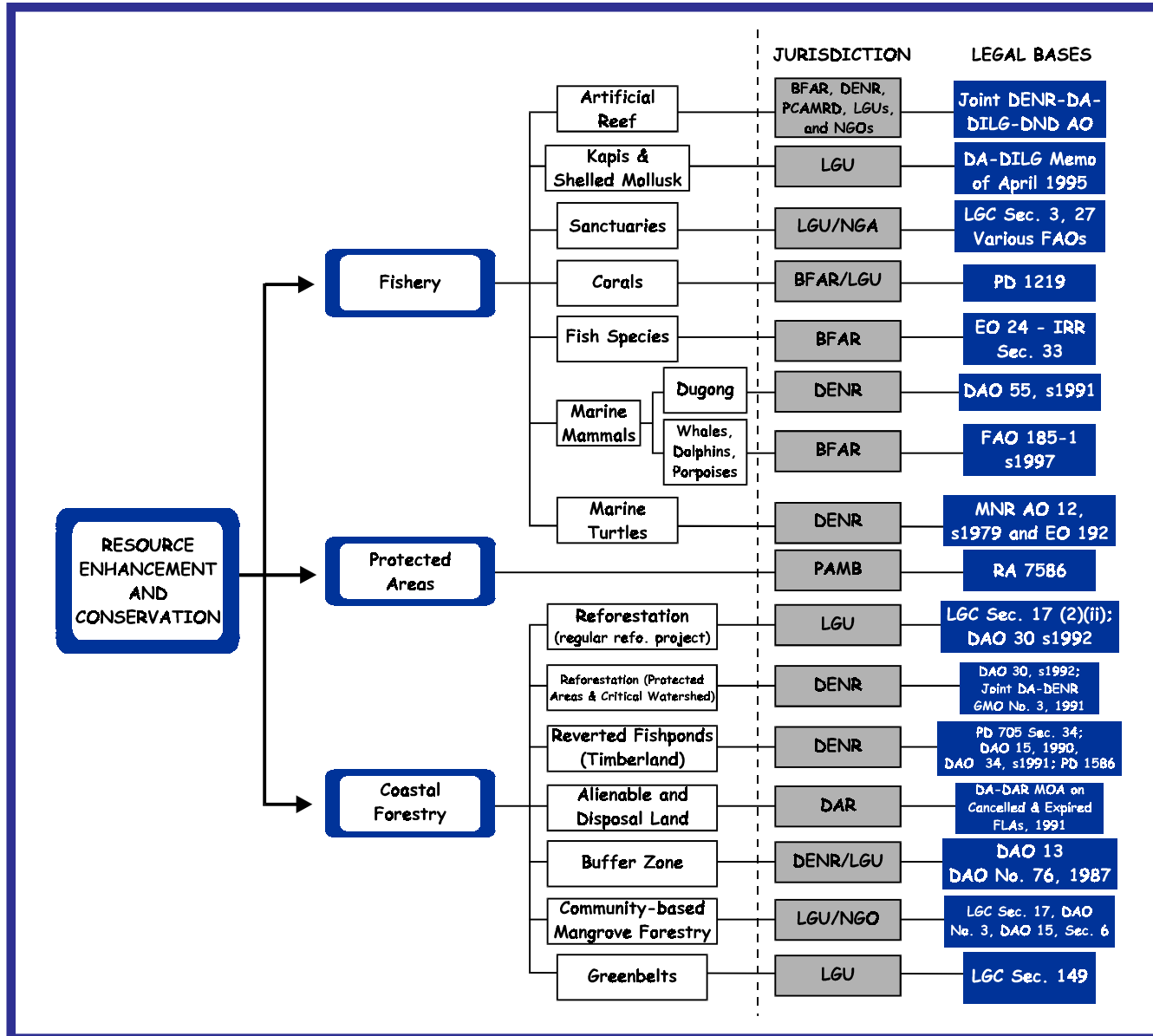

FIGURE 4-13.  
CRM PROBLEM NETWORK  
No. 4: RESOURCE ENHANCEMENT  
AND CONSERVATION



# 4

## CRM Problem Networks and Jurisdictional Authority



the LGU regarding jurisdiction, this document articulates some clarifications.

Aside from the enforcement of existing national laws, municipalities, cities and provinces may also enact ordinances to *protect the environment* (Section 447(a)(1)(vi)), LGC; “*adopt measures to safeguard and conserve land, mineral, marine, forest, and other resources of the municipality*” (Section 444(a)(b)(3)(vii), *ibid.*); “*authorize the establishment, maintenance and operation by the city government of ferries, wharves, and other structures intended to accelerate productivity related to marine and seashore or offshore activities*” (Section 458(5)(iii), *ibid.*); and “*adopt measures and safeguards against pollution and for the preservation of the natural ecosystem in the province, in consonance with approved standards on human settlements and environmental sanitation*”.

### 4.5 DEVELOPMENT ACTIVITIES

The coastal zone comprises critical ecosystems and covers a strategic land-and-water interface that makes it an ideal location for development activities. The huge task of development is assigned to both local governments (LGUs) and NGAs, such as the Philippine Tourism Authority, Public Estates Authority, and Philippines Ports Authority, which have specific mandates. It is often the case that development activities experience a growth spurt with regulation and planning being applied only in an *ad hoc* nature or invoked only during crises. The problem network clarifies the scope of responsibility of LGUs and national agencies (Figure 4-14). The need for LGUs and NGAs to consult, collaborate, and plan in an integrated manner is not apparent in the network but CRMP would like to stress this aspect of development.

A sure sign of progress is land development, including the development of land categorized as public land. Potential issues include rampant conversion of agricultural lands, destruction of coastal ecosystems brought about by reclamation activities, and pollution caused by construction. Land classification activities for LGUs are limited to that of the conduct of cadastral surveys (DAO 30, s1992) with DENR being mainly responsible for the classification of timberlands, mineral lands, protected areas, as well as those belonging to the broad category of public land. LGUs, specifically cities and municipalities, are empowered by the LGC to reclassify agricultural land for residential, commercial, and industrial purposes. However, the DA would have to certify that such conversion is feasible while DENR is tasked to oversee the implementation of the EIS system for land conversion. Foreshore areas are classified as public lands (see 4.36 and 4.38) and can only be disposed of by lease agreements. Reclamation projects can be carried out by provinces and municipalities (LGC, Sec. 17(b)(3)(vii) and Sec. 17(b)(4)) but the PEA is mandated to oversee all reclamation projects.

Tourism is considered a strategic development activity because of its potential to generate foreign exchange and to absorb excess employment from the fishery sector. Tourism-related activities such as diving and swimming may be



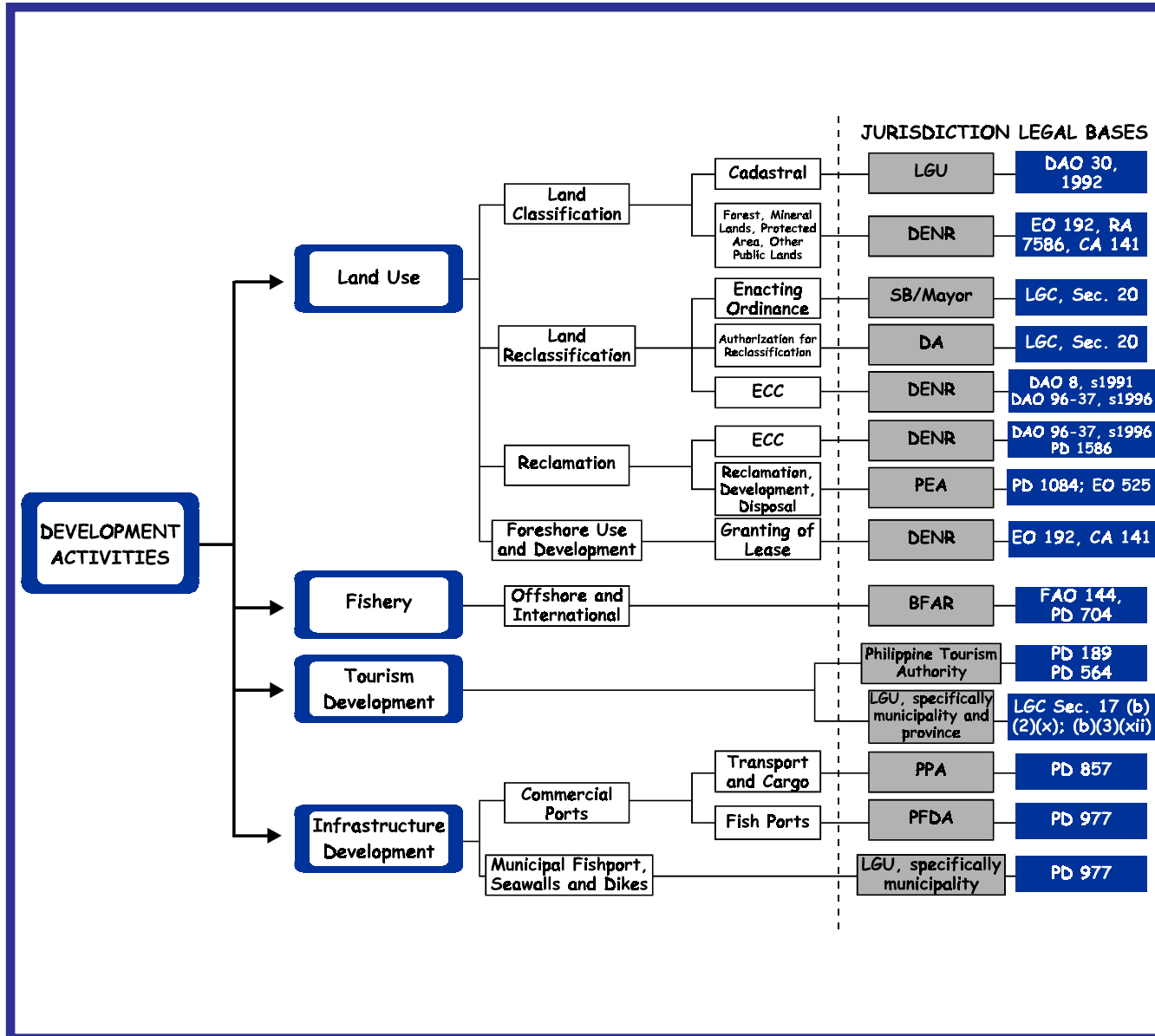

FIGURE 4-14.  
CRM PROBLEM NETWORK  
No. 5: DEVELOPMENT ACTIVITIES



# 4

## CRM Problem Networks and Jurisdictional Authority



less of an extractive nature than fishing but unregulated establishment of tourist operations may also cause environmental stress. Both municipalities and provinces can set up tourist facilities (RA 7160) but it is the Philippine Tourism Authority which coordinates all tourism project plans and operations (PD 189 and PD 564). The role of DENR is to see to it that the EIS system is implemented in tourist sites located in ECAs and in the ECPs (e.g. golf projects). Local governments are empowered to enact ordinances that cater to specific aspects of tourism-induced issues in their localities, like the use of anchor buoys and collection of endangered flora and fauna, which may not have been dealt with adequately and concisely by national laws.